

STEP 5:

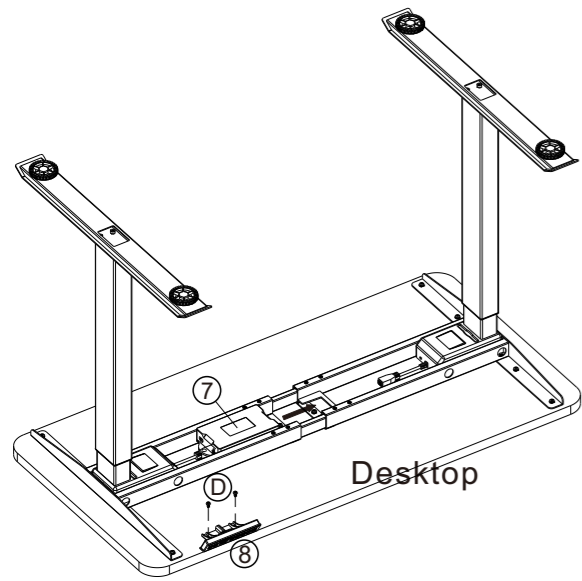

- ⑦ Control Box * 1
- ⑧ Handset * 1
- ⓓ M4×12 Screws * 2

STEP 6:

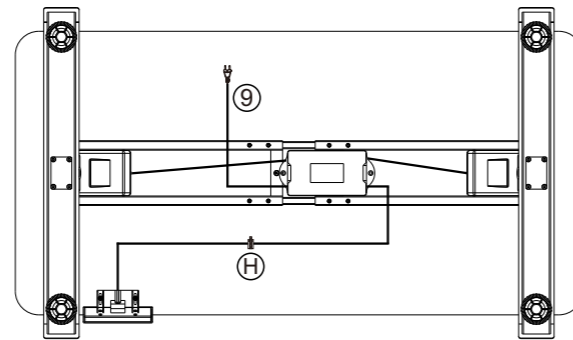

- ⑨ Wires * 2
- Ⓜ Cable Clips * 5

ofika®

Assembly Instruction

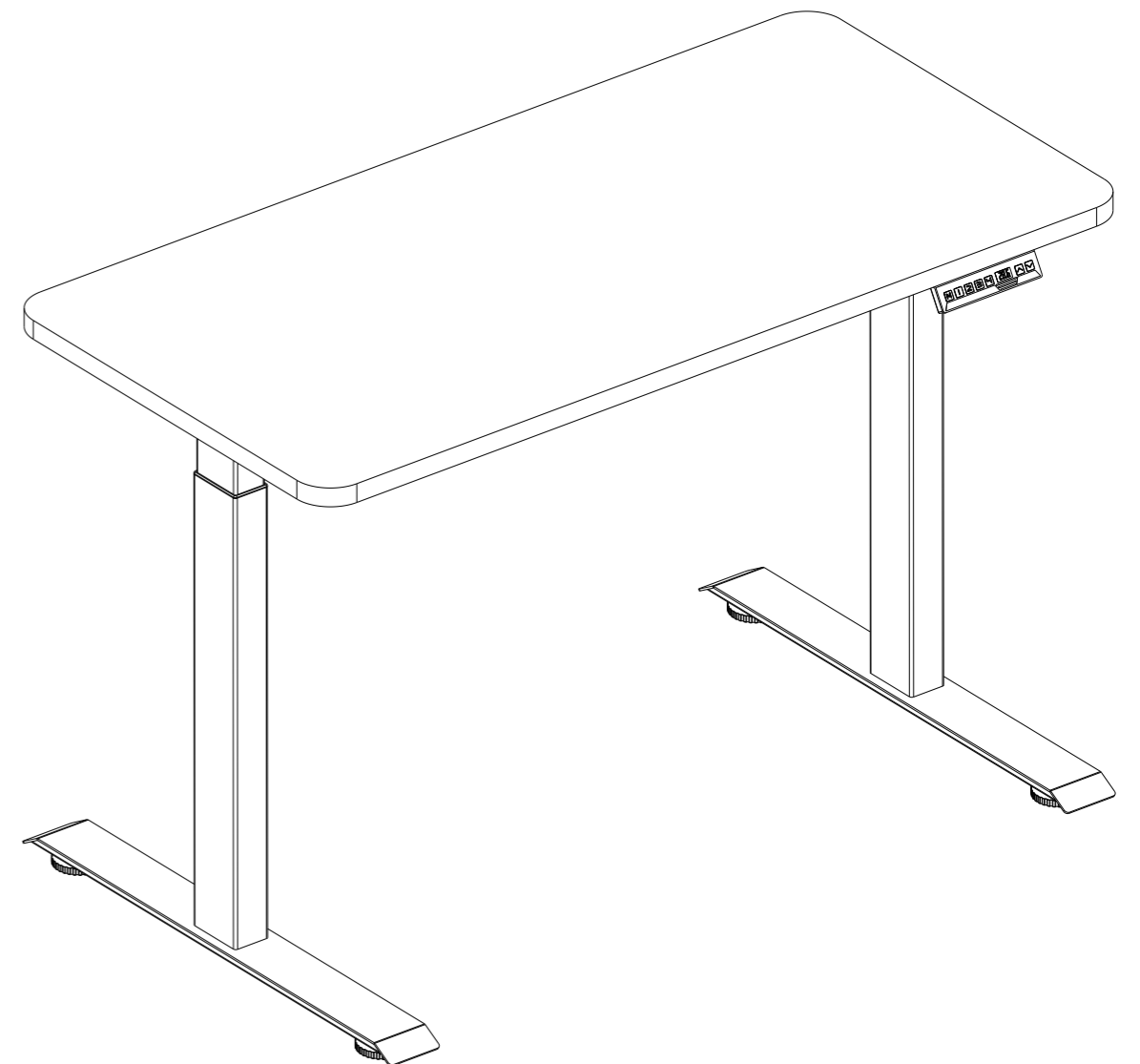

Ready To Use

Before Plugging the table into the outlet, make sure that

- The lift columns are level and set at the lowest position.
- All the screws are tightened, to avoid the desk making noise and wobbling.

Activate the desk by following the next steps.

- Please press button down and hold for 10-15 seconds until it stutters and beeps.
- Release the button, then your desk is ready to use.

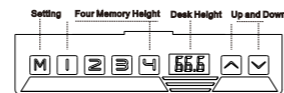

Operation Guide

1. Memory desired height

- Press button "M", display show "S-" with flash.
- Press number and set desired position.

2. Advanced Safety feature- lock and unlock the table.

- Press button up and down at same time for 5 seconds, display "LOC"
- All single button will be inactive and table will be unable to move.
- Pressing button up and down together will unlock the keypad and release the LOC

3. Reset the table

When display show Error code or RST, Please reset the table.

- Unplug the power cord from the control box.
- Unplug the cable that links the keypad to the control box.
- Wait 30 minutes and plug all the cables in again.
- Do the reset: please press button down and hold for 10-15 seconds until it stutters and beeps.

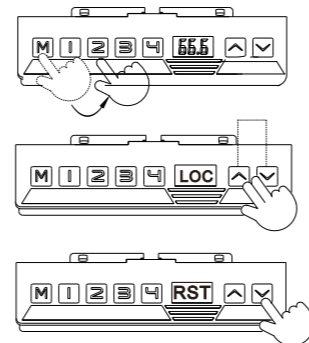

Press by holding
10-15 seconds

If the keypad displays HOT, please unplug and replug and let it cool off for a couple of minutes before proceeding again.

**-Office Desk
-Electric lifting table**

Installation tips



Please don't tighten the screws completely and go back later for a final tightening of all the screws after pieces are aligned with each other.

Lay a mat or old blanket out to assemble onto so the floor and the furniture doesn't get scratched or damaged during building.

Part List

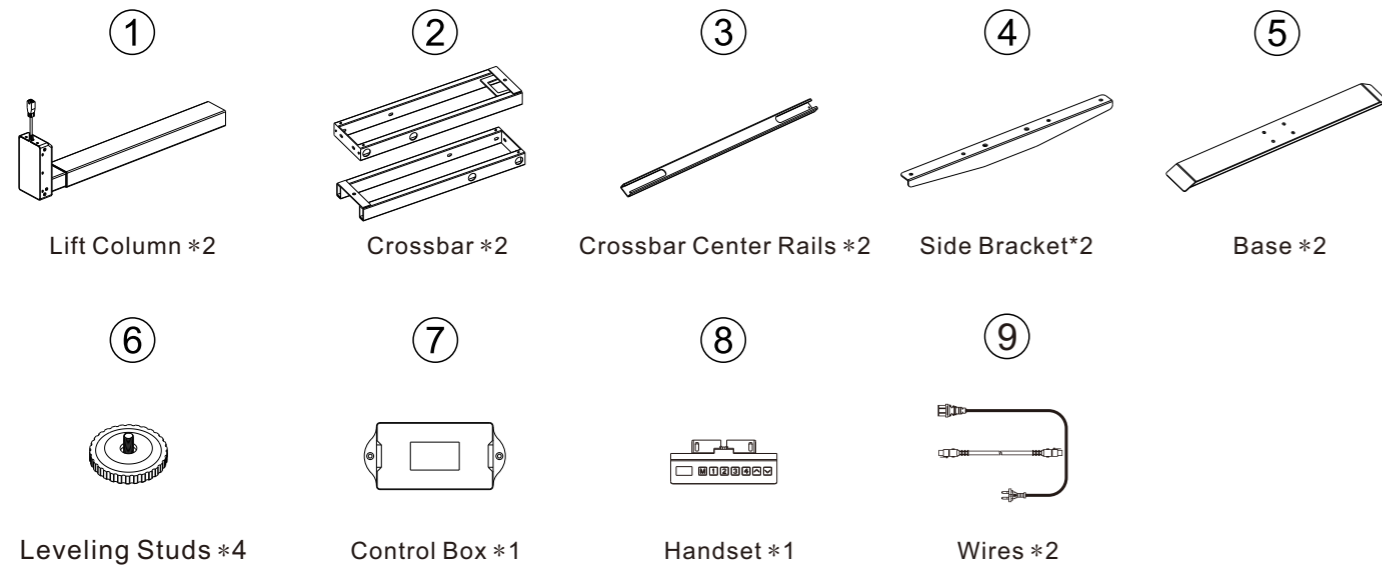

Accessory Kit

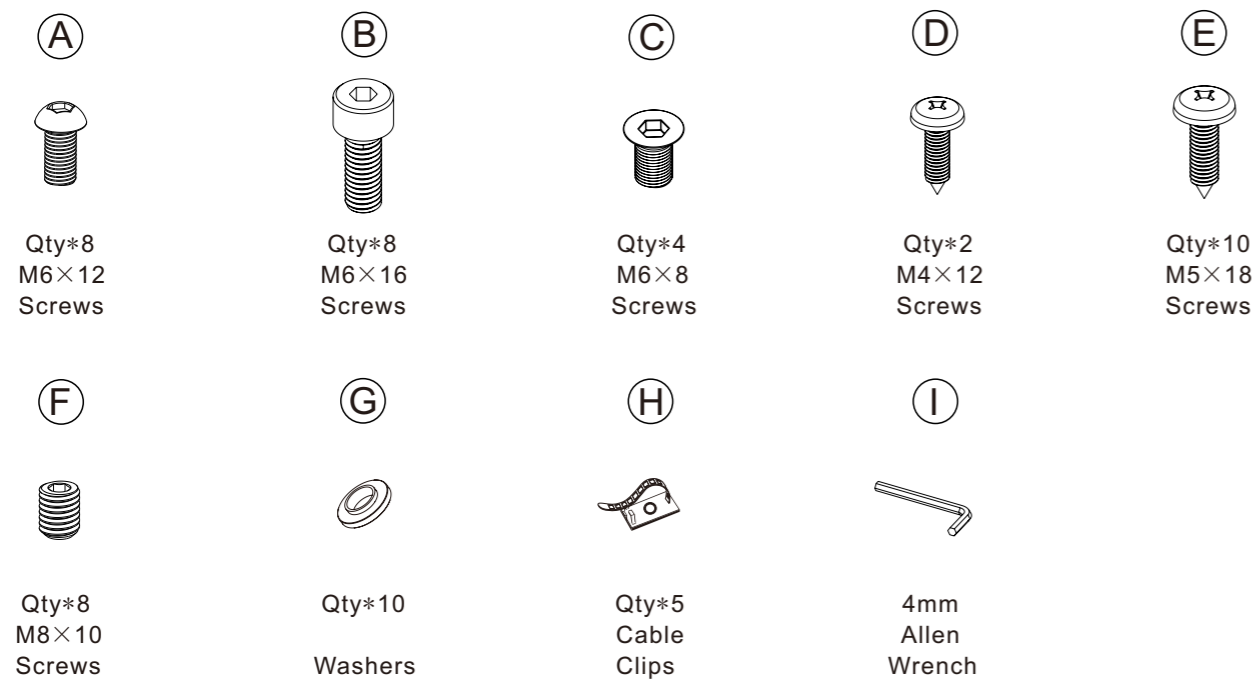

STEP 1:

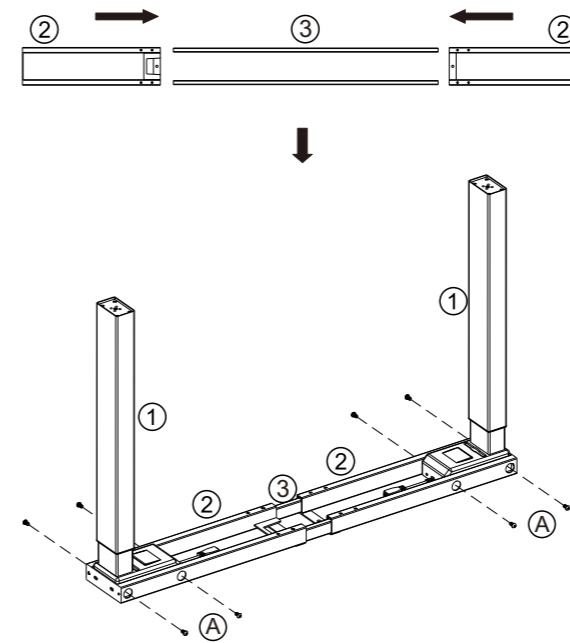

- | | |
|-------------------------|-----|
| ① Lift Column | * 2 |
| ② Crossbar | * 2 |
| ③ Crossbar Center Rails | * 2 |
| Ⓐ M6×12 Screws | * 8 |

STEP 2:

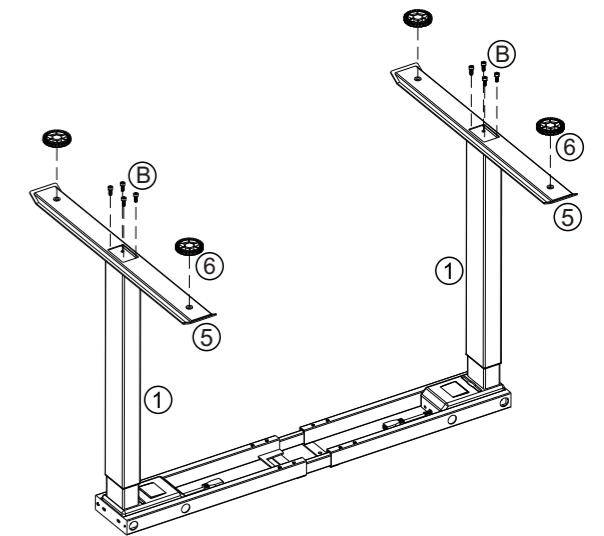

- | | |
|------------------|-----|
| ① Lift Column | * 2 |
| ⑤ Base | * 2 |
| ⑥ Leveling Studs | * 4 |
| Ⓑ M6×16 Screws | * 8 |

STEP 3:

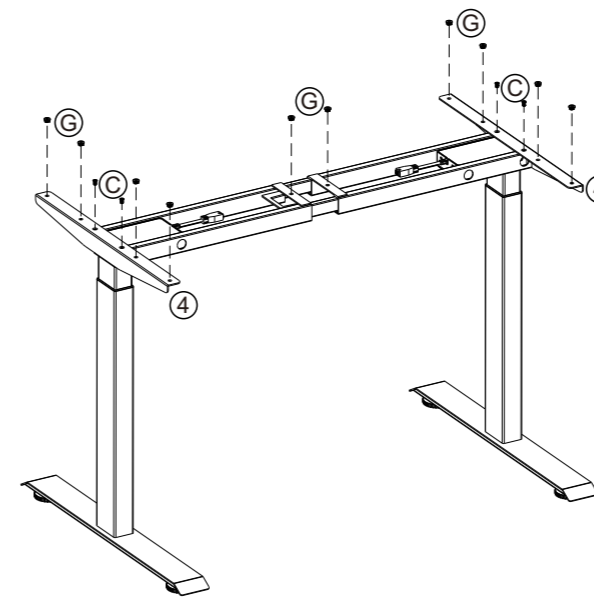

- | | |
|----------------|-----|
| ④ Side Bracket | * 2 |
| Ⓒ M6×8 Screws | * 4 |
| Ⓒ Washers | *10 |

STEP 4:

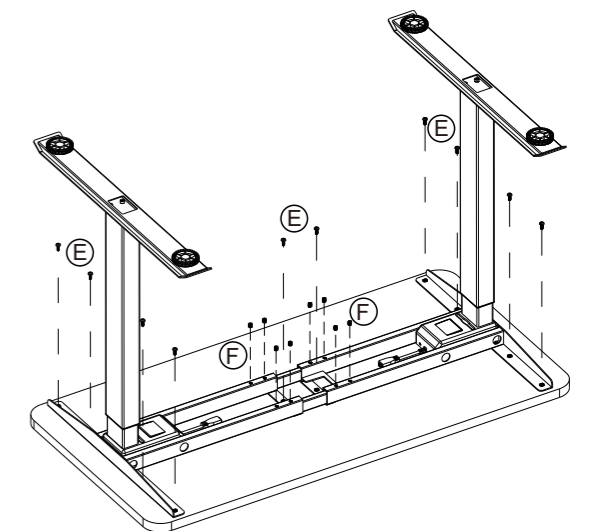

- | | |
|----------------|------|
| Ⓔ M5×18 Screws | * 10 |
| Ⓕ M8×10 Screws | * 8 |